

W2023 E-Workshop

IEEE UBCO Student Branch
In collaboration with UBCO Battlebots

Introduction

About Us

The IEEE Okanagan Student Branch is a hackerspace dedicated to providing students a place to learn and develop technical skills in the field of electrical engineering and electronics design.

We are located in room EME 2245

Hackerspace hours are posted outside the door.

<https://ubcoieee.org/> | <https://linktr.ee/ubcoieee>



IEEE
UBCO STUDENT BRANCH



Introduction

About Myself

I am a 3rd year (undergoing Co-op) Undergraduate Electrical Engineering Student and electronics hobbyist.

I have a background in electronics manufacturing and repair, as well as design experience from hobbies and projects.

Electronics design is not my only hobby, I also enjoy the outdoors and everything it has to offer.

<https://www.linkedin.com/in/bell1024/>



Agenda

Session 1 (1.5 Hours)

- Introduction
- What are Schematics
- KiCad Runthrough
- Schematic Design in KiCad

Session 2 (1.5 Hours)

- Schematic Design in KiCad
- Sourcing Parts
- Bill of Materials

Session 3 (1.5 Hours)

- What is a PCB
- PCB Design in KiCad

Session 4 (1.5 Hours)

- PCB Design in KiCad
- Gerber file export for manufacturing



Schematic Diagrams

What are Schematic Diagrams?

Like all engineering designs, we start with a drawing that illustrates how a system is put together.

In electrical engineering schematic diagrams are used to define the connections between components to create a circuit and describe details like the value, tolerance, and type of each component.

If you are attending this workshop, there is a chance you have seen a schematic or maybe even created your own.

Creating Schematic Diagrams

Being that a Schematic Diagram is simply a drawing, you can make one in various ways. You can use a pen and paper, or software on a computer.

Using EDA CAD software for schematic generation is the default choice in today's age as there are features that save time, making it cost effective compared to drawing by hand.

This workshop covers the open-source EDA CAD software known as **KiCad**.

(EDA) Electronic Design Automation

(CAD) Computer Aided Design



KiCad is an open source EDA CAD software that allows you to draw schematics, design PCB layouts, generate BOMs, and much more.

Alongside the native functions of KiCad, it also supports community plugins allowing for additional functionality and utility.

KiCad instructions and documentation can be found at <https://docs.kicad.org/>

KiCad Application Run-through



Drawing Schematics with KiCad





KiCad - Drawing a Schematic

Definitions:

- Net
 - A net is a single connection between multiple components. Think of this as a node or junction in which components will connect. This is equivalent to the nodes you use while making calculations with Kirchoff's current law.

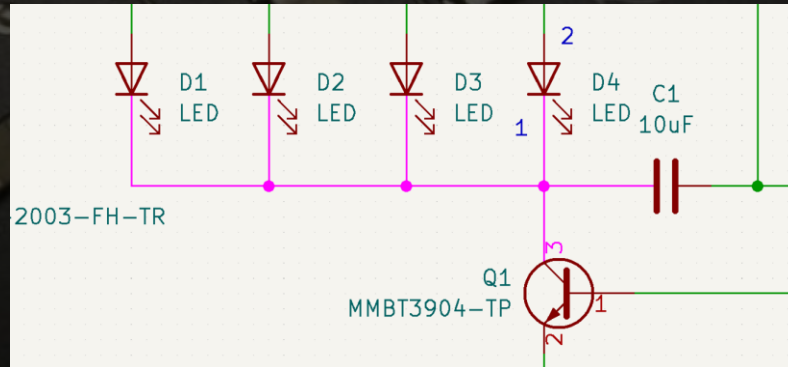



KiCad - Drawing a Schematic

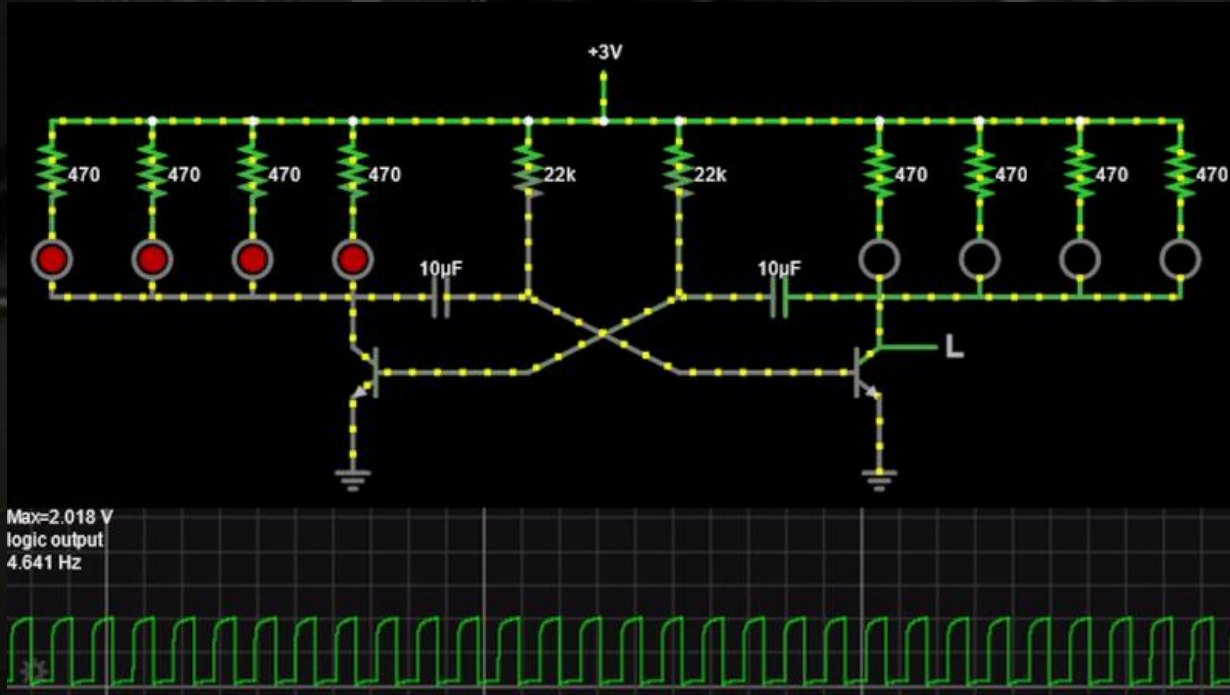



Rules and Best Practice

Rules and Best Practice can be found in:

EW23-01 Rev A - Schematic Design: Best Practice



EW23-01
E-Workshop Supplemental

Schematic Design: Best Practice

By Michael Bell

Purpose

This E-Workshop supplemental document provides strategies and guidelines for electronics schematic design. Most points covered are guidelines and not set rules, however following them will result in a better refined end product.

Contents	
Purpose.....	1
Design Guidelines & Best Practice.....	2
Useful Resources.....	9

Sourcing Parts

DigiKey



**MOUSER
ELECTRONICS.**

Bill of Materials (BOM)





PCB Layouts

What is a PCB?

A printed circuit board (PCB) is a non-conductive substrate that mechanically supports and electrically connects the components using tracks, pads, and other features etched on to a laminated copper sheet.

A PCB populated with components is called a printed circuit board assembly (PCBA)



A Brief History



Point to Point wiring on a chassis



Drawing traces by hand and etching

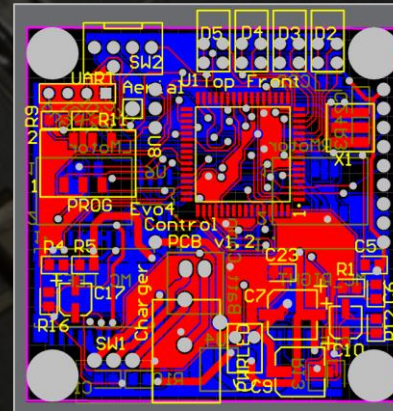

Designing in EDA
CAD Software

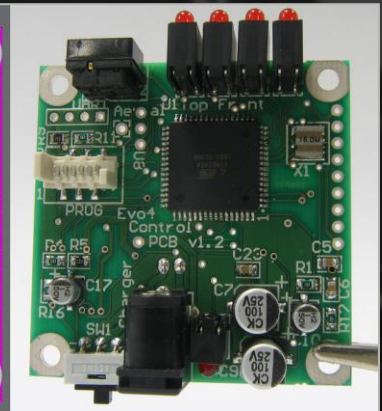

Creating a PCB Layout

Once a schematic is finished, you will probably want to bring the circuit to reality. To do this you need to create a printed circuit board assembly.

There are various methods to accomplish this: Creating one by hand, or using software.

- By Hand: Etching a hand drawn design, or engraving/cutting copper clad.
- Software: EDA CAD software to generate GERBER files*.

In this workshop we will cover the design of a PCB through software.

** With GERBER files you can have your PCB professionally Manufactured or CNC/Laser Engraved.*

Designing a PCB with KiCad





KiCad - Designing a PCB Layout

Stackup:

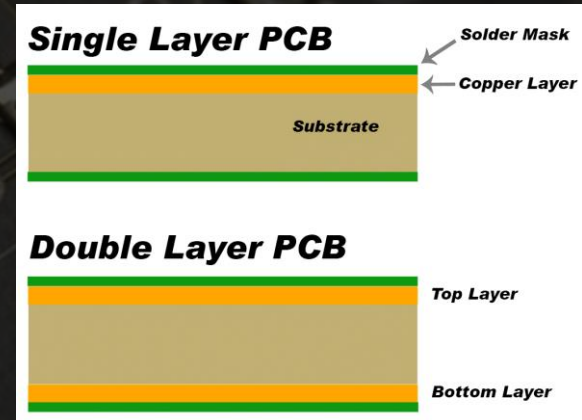
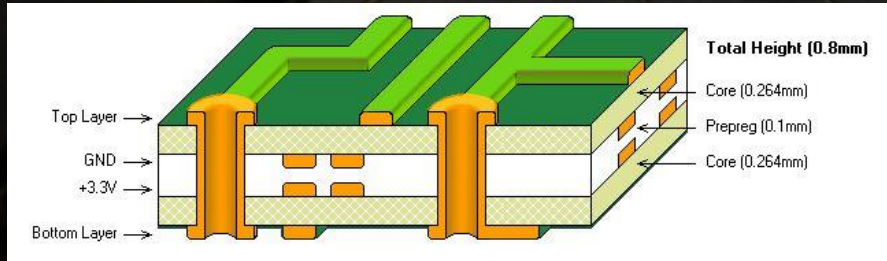



KiCad - Designing a PCB Layout

Stackup:

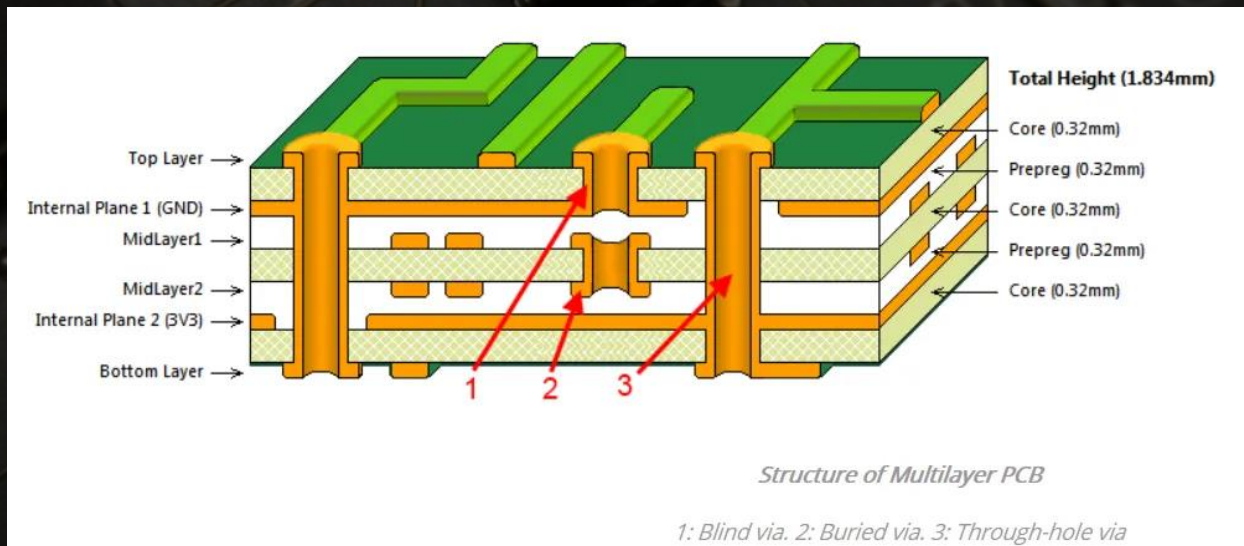



Rules and Best Practice

Rules and Best Practice can be found in:

EW23-02 Rev A - PCB Design: Best Practice



EW23-02
E-Workshop Supplemental

PCB Design: Best Practice

By Michael Bell

Purpose

This E-Workshop supplemental document provides strategies and guidelines for printed circuit board (PCB) design.

Contents

Purpose.....	1
Design Guidelines & Best Practice.....	2
Useful Resources.....	5

Exporting and Viewing Gerber Files



Ordering PCBs from Manufacturers



Thank You for Attending The W2023 E-Workshop!

<https://ubcoieee.org/> | <https://linktr.ee/ubcoieee>



IEEE
UBCO STUDENT BRANCH