

# Schematic Design: Best Practice

By Michael Bell

## Purpose

This E-Workshop supplemental document provides strategies and guidelines for electronics schematic design. Most points covered are guidelines and not set rules, however following them will result in a better refined end product.

## Contents

Purpose.....	1
Design Guidelines & Best Practice.....	2
Useful Resources.....	9

## Abbreviations

SI	International System of Units (Metric)
PCB	Printed Circuit Board
EDA	Electronic Design Automation
CAD	Computer Aided Design

### **Remember**

Good schematics show you the circuit, but bad schematics make you decipher the circuit.

## Design Guidelines & Best Practice

When designing, it is best to follow the following guidelines as closely as possible to give a consistent and well drawn schematic.

### Utilize the snap grid

When using any EDA CAD software, turn on the snap grid and set it to a dimension that will remain constant throughout your drawings. Consistency in your schematics is key to ensuring your schematics remain clear.

### Signal and Voltage Flow

A schematic layout should have the signal path going from left to right. With feedback signals going right to left, as they are “feeding back”. It is best to have the higher voltage connections close to the top of the page, and lower voltage connections close to the bottom of the page. Power connection symbols should always be vertical, with positive voltages pointing up and negative voltages (including ground) pointing down.

### Design on standard paper size

Design your schematic so that they are readable on a standard printer size paper like A4 or 8.5”x11”. This allows them to be easily printed. For larger circuits, you may need to design the schematic over multiple pages to keep your drawings organized and readable.

### Text Font

Text on the schematic should be uniform, simple, and every character should be easily legible at all font sizes. For that reason fonts that are very vector-like, with straight lines, unambiguous, are best. Make sure the font you choose has good spacing to prevent symbols such as underscores from being covered by other lines in the schematic such as symbols or wires. Common fonts to use are Arial, Consolas, or Tahoma.

In addition to font, always make text for components, nets, labels, notes, etc. ALL CAPS.

### Text placement

Adjust the placement of the text associated with a symbol to not overlap other text and to make the text orientation consistent.

It is good practice to have the designators and values on either side (or occasionally on the top and bottom) of horizontally oriented components and on the right side above and below vertically oriented components as shown below.



## Defining Junctions

Draw a dot at every junction and make all junctions T's. Do not draw 4-way cross junctions. With two lines crossing, one vertical the other horizontal, the only way to know whether they are connected is whether the junction dot is present. This can be affected by issues regarding photocopying or image compression of the schematic. When photocopied or compressed, the junction dots can fade, disappear, or reappear in places they shouldn't.

When drawing or reading schematics, the general rule is if two lines cross then they are never connected, even if after some reproduction or compression artifacts it looks like there maybe is a dot there. By making all junctions Ts with dots, all crossing lines are therefore different nets without dots.

In addition to this, never use an arc to indicate one net crossing over another. This is an old method and considered bad practice.

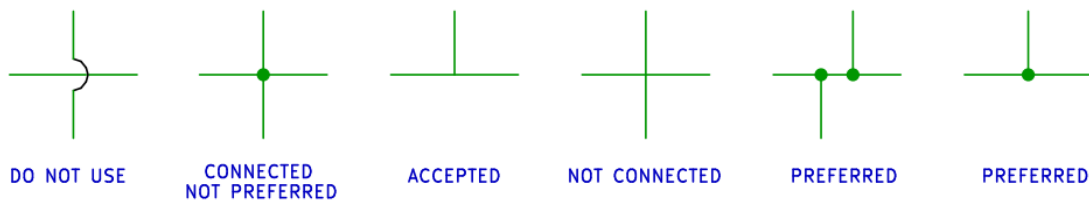

## Keep symbols consistent

Always use the same symbol for the same device. For instance, there are multiple ways to draw different types of resistors, capacitors, logic gates, etc. When drawing these symbols, choose one symbol for the device and keep it consistent throughout your project's schematics.

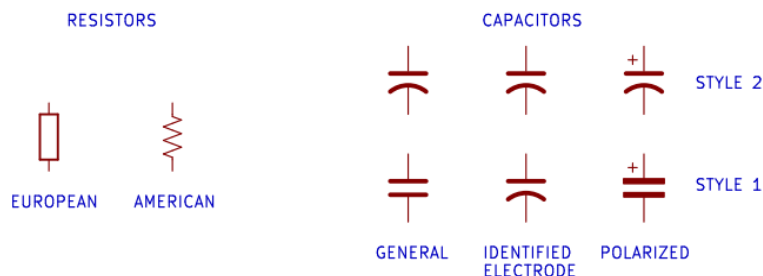

## Break it down into blocks

Break down your design into blocks based on functions, signal types, voltage domains, etc. Doing this will make designing on multiple pages easier, troubleshooting quicker, and overall improve organization. Adding a block diagram to the first page of your schematic package will also improve organization and searchability.

## Common Circuits

When drawing known building blocks and sub-circuits, draw them as they are commonly known and ensure they are recognizable. An example of this would be a common emitter amplifier. The

drawing on the left is easily recognizable as a common emitter amplifier, while the drawing on the right is hardly recognizable.

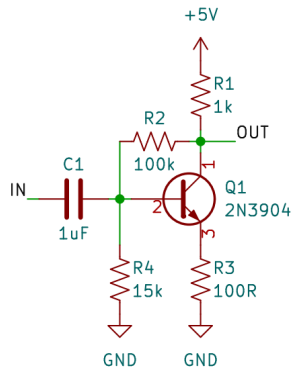

IDENTIFIABLE AND UNAMBIGUOUS

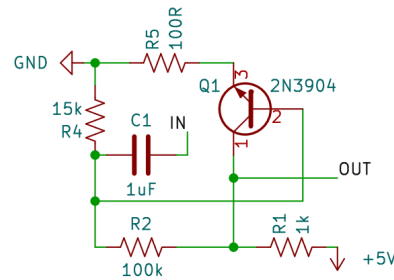

OBFUSCATED AND UNRECOGNIZABLE

### Draw pins according to function

Show pins of ICs in a position relevant to their function. Following the signal path and layout, when drawing an IC, have the voltage inputs at the top, grounds and negative voltages at the bottom, inputs on the right, and outputs on the left. Physical pin order layouts obfuscate the circuit, so it is best to avoid.

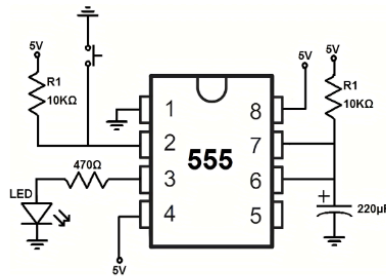

Physical Pin Layout

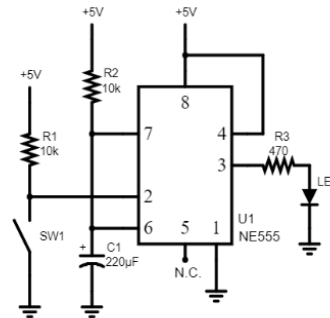

Functional Pin Layout

### Spacing

Leave enough space between pins to make the pins readable and consistent. A good rule of thumb for this is to leave enough space so you can add resistors on top of each other with room for text (this is particularly helpful when adding resistor arrays).

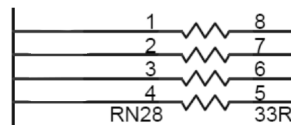

### Wires and busses

When designing a schematic with parallel logic or wires that should be grouped together, use a bus where possible. A bus will group the wires and show as one thick wire on the schematic. This saves space, and increases readability. Avoid crossing busses if possible as this can be ambiguous.

### Net names

Placed directly on a “wire” connection, explicit net names are used to clarify the purpose of a signal, or label a specific type of signal. A common use for net names is to name the signals on connector pins. In most EDA CAD software, nets are global, so they can be used across multiple pages of a schematic to define connections.

### Use ports/labels for distant connections

When designing schematics that have connections spanning the entire page, or multiple, it is better and more organized to use a label instead of drawing a wire to connect the two points. In the case of a multi-page schematic, labels are necessary. Use direct wires where possible, but use labels to connect the less direct connections.

### Decoupling capacitor placement

Because of the purpose of decoupling capacitors, they need to be physically placed very close to the part. On a schematic, it is best practice to place decoupling capacitors by their IC power pins. This makes the intent of the component clear, and can prevent mistakes later in the PCB design process.

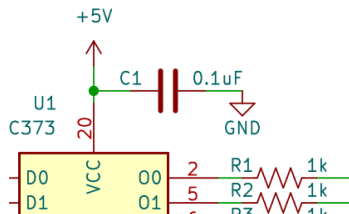

### Standard component values

When designing a circuit in a simulation or calculating values, components may have specific and non-standard values. This could be along the lines of a 1.0634 kOhm resistor, which does not exist as a physical part you can acquire. So unless it is a critical value, not using standard values will only make manufacturing and parts sourcing extremely difficult or impossible.

Standard values for resistors, capacitors, and inductors most commonly follow the E-Series of preferred numbers, details of which are explained in the IEC 60063:2015 standard. You can also go to [https://en.wikipedia.org/wiki/E\\_series\\_of\\_preferred\\_numbers](https://en.wikipedia.org/wiki/E_series_of_preferred_numbers).

For fuses, standard values follow the Renard series of preferred numbers, more of which can be found in the ISO 3:1973 standard or at [https://en.wikipedia.org/wiki/Renard\\_series](https://en.wikipedia.org/wiki/Renard_series)

More on this topic can be found in RD23-00 Rev A - Component Marking Systems.

### Value notation and tolerance

While giving capacitors, inductors, and resistors values, use metric system international (SI) suffix letters in place of the decimal point. As schematics get routinely photocopied or otherwise optically reproduced, decimal dots can disappear after a few generations. To prevent fidelity errors this convention was adopted. As a bonus, it makes values shorter and quicker to read. SI suffix letters used are shown in Table 1.1.

Table 1.1 Component Value Numbering

Letter	Unit	10 <sup>^</sup>	Used for	Example
p	Pico	-12	Capacitors	33p for 33pF, 8p1 for 8.1pF
n	Nano*	-9	Capacitors, Inductors	2n2 for 2.2nF, 39n for 39nH
u	Micro	-6	Capacitors, Inductors	4u7 for 4.7uF, 10u for 10uH
m	Milli	-3	Capacitors, Inductors, Resistors	1m for 1mF, 3m3 for 3mF
k	Kilo	+3	Resistors	2k2 for 2.2k Ohms, 22k for 22kΩ
M	Mega	+6	Resistors	3M3 for 3.3 M Ohms
R	Ohm	0	Resistors Only**	37R5 for 37.5 Ohms, 220R for 220 Ω

\* Using nano (n) for capacitors and inductors is not typical in industry. It is more common to use micro (u) and pico (p). Ex. 2200p for 2.2n or 0u8 for 800n

\*\* For base values, use R in place of the decimal for Resistors. Base values for capacitors and inductors are not common, so this notation does not apply.

When writing out the component value, use 3 characters (including the SI letter) to denote a 5% tolerance, use 4 characters to denote 1%, and use 5 characters for 0.5/0.1%. Ex. 1M0 for 1M Ohms 5%, 4u70 for 4.7uF 1%, 2k210 for 2.21k Ohms 0.1%.

Alternatively for tolerances, you can make an engineering note on the drawing that states a default tolerance for a component type, then when you deviate from that tolerance you can add the tolerance value next to the component value.

### Reference Designators

Make sure reference designators are visible, clear, and at the components side in the same orientation as all other reference designators. Most EDA CAD softwares have default reference designators, and the ability to add your own. Common reference designators can be found in table 1.3 below.

Table 1.3 Common Reference Designators (Sorted by component type)

(Note: Blue designators are optional and/or meant for large circuits where discrimination between components is necessary or advantageous)

Ref.	Description
R	Resistor, All kinds.
RA	Resistor Array.
VR	Variable Resistor, Potentiometer. (Replaces R designator for Variable Resistor)

C	Capacitor, All Kinds.
CA	Capacitor Array.
VC	<a href="#">Variable Capacitor. (Replaces C designator for Variable Capacitor)</a>
D	Diode, All kinds (including LEDs).
TVS	<a href="#">Transient Voltage Suppression Diode. (Replaces D designator for TVS)</a>
L	Inductor, All Kinds (Excluding transformer).
T	Transformer.
FB	Ferrite Bead.
F	Fuse..
Q	Discrete Transistor.
U	Integrated Circuits (Including Voltage Regulators, microcontrollers, and SoCs).
SW	Switch, Button.
K	Relay.
BAT	Battery Clip.
J	Jack (Least movable connector of a connector pair).
JP	Jumper Connector (Link on Board) .
P	Plug (most-movable connector of a connector pair).
A	Sub-module or PCBA.

More information on reference designators can be found in IEEE Standards. Companies may also have their own practice when it comes to reference designators.

### **A Strategy for Reference Designator Numbering**

If you split up the circuit into blocks according to function, such as “main power stage”, “amplifier”, “A/D conversion stage”, “discrete logic”, etc. it is beneficial to number your reference designators using larger numbers R100, R101, R102 instead of R1, R2, R3... so on. You can assign 100, 200, 300... for each block you identified. For example, you can assign 100 to 199 numbers for the “main power stage” section. Then all components in the power section are in 1xx form such as Q100, R101, R103, C100, D100, D106.

Benefits to employing this strategy:

- Makes the sections of a circuit in a complex schematic diagram easy to identify and easy to troubleshoot.
- Easy to remove or add components without having to renumber all reference designators.
- Makes designing a PCB in an EDA application easier, as the components will be sorted by reference designators.

**Multi Part packages**

Multi part packages such as Quad Op Amps (4 op amps in one chip) or a hex inverter (6 inverters in one chip) may show up in schematics as U2A, U2B, etc. Make sure that all of the parts get “packaged” into the minimum number of IC packages required. If there are parts that aren’t being used, such as 5 of the 6 inverters being used in a hex inverter, connect the pins of the unused part to a potential or ground (based on the part and pin) to prevent any possibility of interference, crosstalk, or oscillations from occurring.

**Part orientation**

When drawing parts on a schematic such as an Op Amp, make sure not to flip the orientation in such a way that it is less commonly perceived. In the case of most op amps, they are drawn with the non-inverting input above the inverting input. Because this is “upside down” from the way students see Op Amps drawn, they may flip the Op Amp orientation to match what they are used to. However, when this happens, the positive power pin will point down and the negative pin will point up, which can cause errors as someone may miswire your design if you start flipping parts. The convention is that the positive power pin is up and the negative pin is down.

## Useful Resources

Topic	URL
Preferred Numbers	<a href="https://en.wikipedia.org/wiki/E_series_of_preferred_numbers">https://en.wikipedia.org/wiki/E_series_of_preferred_numbers</a> <a href="https://en.wikipedia.org/wiki/Renard_series">https://en.wikipedia.org/wiki/Renard_series</a> <a href="https://onlinelibrary.wiley.com/doi/pdf/10.1002/9781119598961.app7">https://onlinelibrary.wiley.com/doi/pdf/10.1002/9781119598961.app7</a>
Reference Designators	<a href="https://en.wikipedia.org/wiki/Reference_designator">https://en.wikipedia.org/wiki/Reference_designator</a>